

T9000 Sun-4 network interface software

PRODUCT INFORMATION

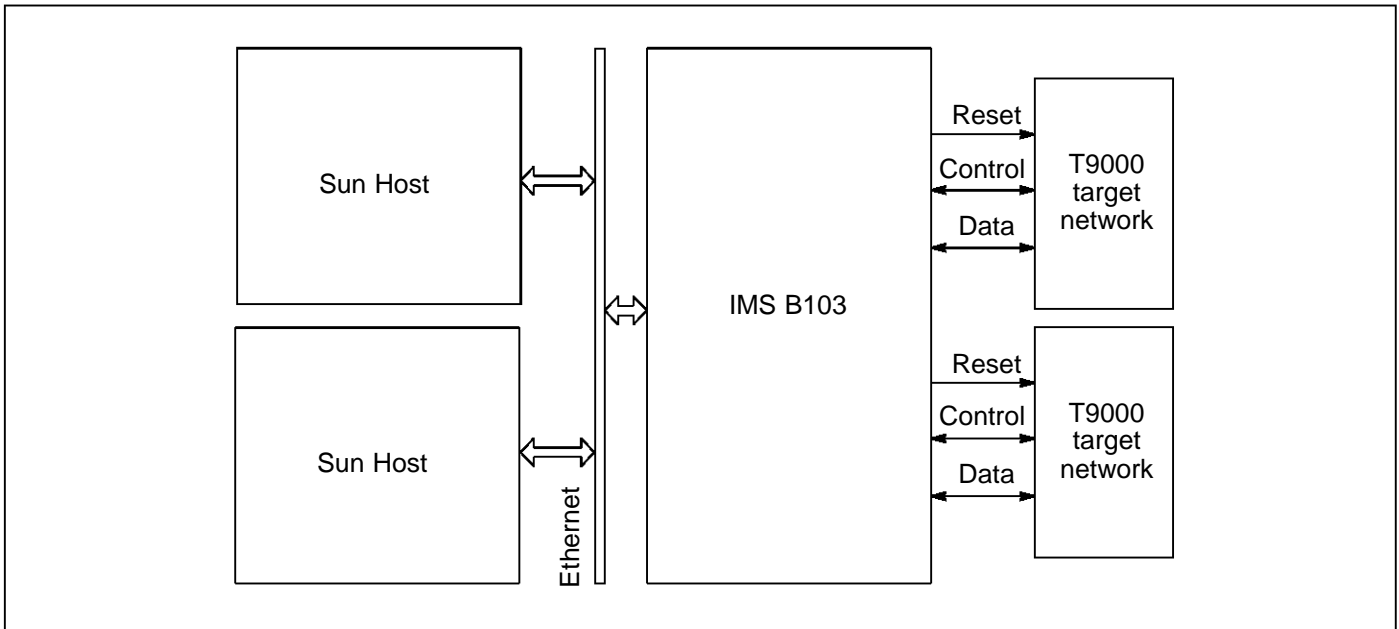

**FEATURES**

- Development interface package for networked access to T9000 target hardware.
- Configuration of T9000 networks and booting of programs produced using the T9000 toolsets.
- *iserver* based runtime support of T9000 programs.
- Support for INQUEST debugging and profiling.
- AServer libraries to enable user specific servers to be created.
- Support for Sun-4 hosts with X-Windows.
- No hardware installation required in development host.

**DESCRIPTION**

The IMS S4397 product is used in conjunction with the T9000 software development toolsets and the IMS B103 Ethernet to DS-link interface to form a complete networked, multi-user development environment for T9000 application programming. The products enable users to configure and boot applications, to provide input and output to the application, and to use INQUEST to perform interactive and post-mortem debugging.

## **1 Product overview**

The purpose of the network interface software is to provide a software interface across an Ethernet network between a Sun-4 host and software running on an IMS T9000 target network. The IMS S4397 supports interface hardware such as the IMS B103 Ethernet to DS-Link interface board.

The IMS S4397 product is used in conjunction with the T9000 software development toolsets and the IMS B103 Ethernet to DS-link interface to form a complete networked, multi-user development environment for T9000 application programming. It may be used in conjunction with the T9000 ANSI C or T9000 occam 2 Toolset products and the INQUEST debugging and profiling tools.

The network interface software provides a simple interface for running IMS T9000 applications. It also provides a flexible framework for users who wish to customize the host server for their own requirements. The product enables users to:

- S configure and boot applications onto T9000 networks;
- S provide input and output to the T9000 application;
- S use INQUEST to perform interactive, post mortem debugging and profiling of the application;
- S build customized hosted user interfaces for T9000 applications.

The AServer is a standard mechanism for allowing user defined communication with a transputer based application at the same time as that application is using standard run-time library interfaces or being debugged using INQUEST. The flexibility offered by the AServer allows independent service activity to be supported across the network without mutual interference. Service modules developed for use with the AServer can be simple or complex and are compatible with existing transputer environments.

## **2 Example development environment**

Figure 1 shows an example of use of the IMS S4397 with the IMS B103 interface board to provide two independent T9000 development environments.

The figure shows the software that would be running when two users with Sun hosts are each accessing one T9000 target network. The application loader `irun` is running on each host and each `irun` has configured its target network and loaded an application program onto the target.

Both application programs have been configured with the INQUEST debugging option, so in each case `irun` has started the INQUEST debugger on the host and is handling communications between INQUEST and the debugger kernels on the target. Both programs have performed some host I/O, (perhaps opening a file for reading), causing `irun` to start an `iserver` service which implements this I/O. Finally, for one of the applications the user has produced a customized AServer service – perhaps providing a graphical user interface to the application, for example.

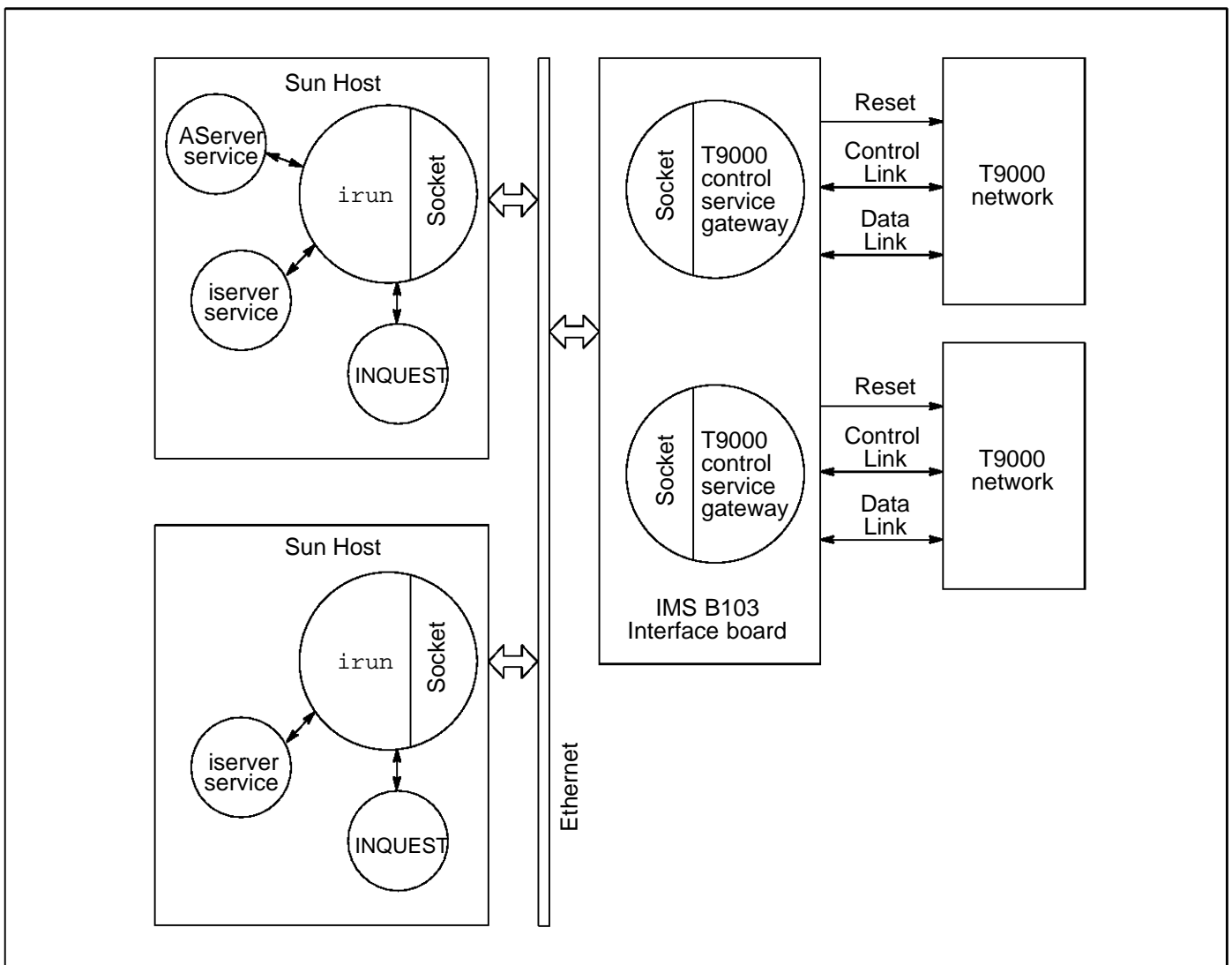

Figure 1 Example development environment for T9000 application programming

### 3 Product description

The IMS S4397 product includes the following software:

- S a TFTP bootable module for the IMS B103 Ethernet to DS-Link interface that enables its use as a two-user T9000 network development interface;
- S **irun** application loader utility for the host environment;
- S **iserver** run-time support server for the T9000 Toolset environment;
- S AServer programming interface for the host and T9000;
- S AServer example programs;
- S an example AServer connection database **aservdb**;
- S a T9000 network analyzer **t9spy**.

Full installation and user documentation is supplied.

## **4 Product environmental requirements**

The IMS S4397 software package is designed to be used in conjunction with the T9000 ANSI C and occam 2 toolset products and the T9000 INQUEST product. It is only compatible with an IMS B103 Ethernet to DS-Link interface board.

The IMS S4397 product requires a Sun-4 workstation or server machine and will only run under the SunOS operating system version 4.1.3 or later or under the Solaris operating system version 2.4 (SunOS 5.4) or later.

## **5 Ordering information**

<b>Description</b>	<b>Order Number</b>
IMS S4397 Sun-4 Network Interface Software	IMS S4397

Table 1 Ordering information

## **6 Field Support**

SGS-THOMSON products are supported worldwide through SGS-THOMSON Sales Offices, Regional Technology Centers and authorized distributors.

Information furnished is believed to be accurate and reliable. However, SGS-THOMSON Microelectronics assumes no responsibility for the consequences of use of such information nor for any infringement of patents or other rights of third parties which may result from its use. No license is granted by implication or otherwise under any patent or patent rights of SGS-THOMSON Microelectronics. Specification mentioned in this publication are subject to change without notice. This publication supersedes and replaces all information previously supplied. SGS-THOMSON Microelectronics products are not authorized for use as critical components in life support devices or systems without express written approval of SGS-THOMSON Microelectronics.

© 1996 SGS-THOMSON Microelectronics - Printed in Italy - All Rights Reserved  
IMS, occam and DS-Link are trademarks of SGS-THOMSON Microelectronics Limited.

 is a registered trademark of the SGS-THOMSON Microelectronics Group.

SGS-THOMSON Microelectronics GROUP OF COMPANIES  
Australia – Brazil – Canada – China – France – Germany – Hong Kong – Italy – Japan – Korea – Malaysia – Malta – Morocco  
The Netherlands – Singapore – Spain – Sweden – Switzerland – Taiwan – Thailand – United Kingdom – U.S.A.